

AVENTO



AVENTO - brushed stainless steel
500 x 790 mm



AVENTO - anthracite coated
905 x 480 mm

AVENTO



AVENTO
brushed stainless steel
600 × 1630 mm

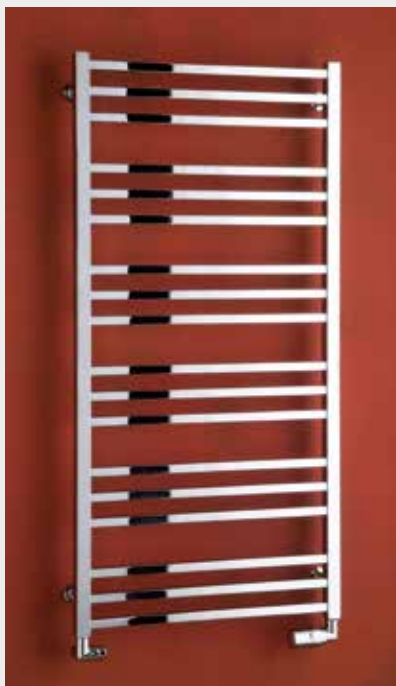

AVENTO - chrome
600 × 1210 mm



AVENTO - white coated
600 × 1210 mm



AVENTO - metallic silver coated
600 × 790 mm



AVENTO - valve CUBE-CET
chrome



AVENTO - valve CUBE-COM
chrome

Location of "attachment" to the wall: ↓ 80 mm ↑ 80 mm
 Central heating: YES
 Combination heating: YES
 Electric heating: YES

Connection options:

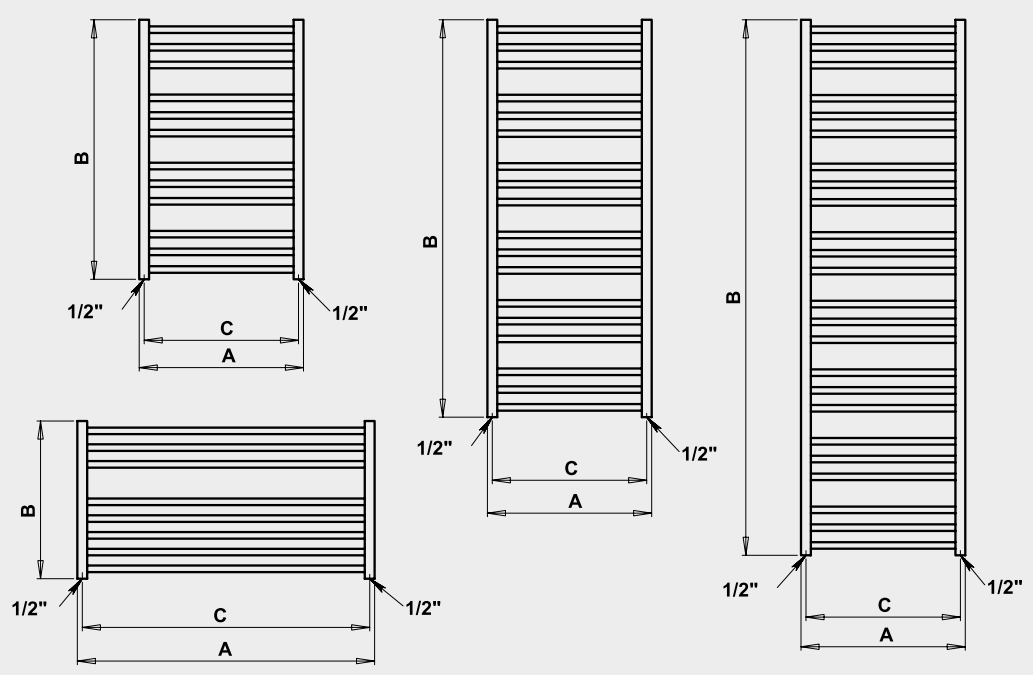
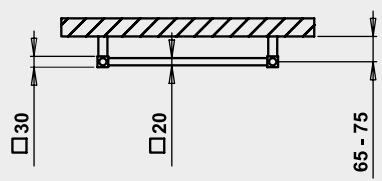
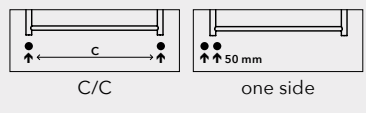

Chrome**	Brushed stainless	White coated	Other surface finish (coated)*	Width (A) x Height (B) [mm]	HO [W] Δt 20°C***		Weight [kg]	Content [l]	Connection span (C) [mm]	Max. recommended electric heating element [W]
					75/65°C	55/45°C				
AV1C	AV1SS	AV1W	AV1	500 × 790	310	161	7,5	2,7	470	200
AV2C	AV2SS	AV2W	AV2	600 × 790	407	212	8,5	3,0	570	300
AV3C	AV3SS	AV3W	AV3	500 × 1210	468	243	11,1	4,0	470	300
AV4C	AV4SS	AV4W	AV4	600 × 1210	588	306	12,9	4,6	570	300
AV5C	AV5SS	AV5W	AV5	500 × 1630	622	323	14,8	5,3	470	400
AV6C	AV6SS	AV6W	AV6	600 × 1630	783	407	17,2	6,2	570	500
Horizontal design										
AVLC	AVLSS	AVLW	AVL	905 × 480	422	219	8,7	2,7	875	300
AVXLC	AVXSS	AVXLW	AVXL	1210 × 480	484	252	11,2	3,4	1180	300

*Other surface finishes see page 78. **Heat output of chrome versions can be 20% lower.

***Calculation of temperature gradients can be viewed on www.pmh-co.cz.

- L and XL versions are not recommended for use with electric heating element.